	Solaris Standars & Recommended Practices	
	Motion control standard	Page 1 of 21
	Final version	Date 2021-11-05
		Version: 1.8

Motion control standard

Revision:	1.8
Status:	Final
Owner:	Ireneusz Zadworny ireneusz.zadworny@uj.edu.pl
Reviewed by:	Michał Piekarski michal.piekarski@uj.edu.pl
Approved by:	
ECM location:	Beamlines_Solaris_Standard_Recommendation
Filename:	Motion Control Standard.doc
Last update:	2021-11-05

Revision history

Version	Date	Description	Sign
0.1	2013-07-23	First draft	Lukasz Zytniak
1.0	2017-01-13	Final version	Lukasz Dudek,
1.1	2017-01-20	Editorial changes	Tadeusz Szymocha
1.2	2017-01-23	Editorial changes	Tadeusz Szymocha
1.3	2017-04-03	Appendix 9.3 added	Tadeusz Szymocha
1.4	2018-02-01	Ownership changed	Tadeusz Szymocha
1.5	2019-05-14	Editorial changes	Ireneusz Zadworny
1.6	2019-10-02	Updated and reviewed	Michał Piekarski
1.7	2021-06-14	Tables in appendix fixed	Michał Piekarski
1.8	2021-11-05	Add sub-d 9pin encoder standard	Michał Piekarski

Authors:

Julio Lidón-Simón
 Lukasz Zytniak
 Lukasz Dudek
 Tadeusz Szymocha

	Solaris Standars & Recommended Practices	
	Motion control standard	Page 2 of 21
		Date 2021-11-05
Final version	Version: 1.8	

Spis treści

1	Introduction.....	3
2	Motor controller.....	3
3	Standard motion system.....	4
3.1	Motors.....	4
3.2	Motor connection.....	4
3.2.1	Connector code examples (based on Souriau Trim Trio series).....	5
3.2.2	Alternative motor connection for in-vacuum stepper motors up to 2A*.....	5
3.3	Encoders.....	7
3.4	Limit or home switches.....	9
3.5	Temperature connectors.....	9
3.6	Disable.....	9
3.6.1	Disable with no need of external electronics.....	10
3.6.2	Disable with need of external electronics.....	10
4	Non-standard motion systems.....	11
5	Dampers.....	13
6	Brakes.....	13
7	Cabling.....	14
8	Documentation.....	15
9	Summary.....	16
10	Appendix A.....	17
10.1	Standard motion system. Motor connector wiring example.....	17
10.2	Standard motion system. Disable connection wiring examples.....	18
10.2.1	Overtravel or safety switch limits to PLC and from there to IcePAP.....	18
10.2.2	Overtravel or safety switch limits direct to IcePAP.....	19
10.3	Motion parameters (template).....	20

	Solaris Standards & Recommended Practices	
	Motion control standard	Page 3 of 21
		Date 2021-11-05
Final version	Version: 1.8	

1 Introduction

This document summarizes the SOLARIS standards on motion control and pretends to advice on best practices in motion cabling.

2 Motor controller

National Synchrotron Radiation Center - SOLARIS standard motor controller is IcePAP.

As mentioned in the introduction, this document describes SOLARIS policies while the document 'IcePAP Hardware Manual' is the ultimate reference for the IcePAP motor controller itself. Both documents should be distributed together.

IcePAP driver can drive virtually any kind of 2 phase bipolar stepper motor and provide signals to steer any kind of external pulse/direction driver used to power a motor of other technology. IcePAP has four main interfaces that will be described in the following sections.

In the Figure 1 appear all the different elements of a standard motion system with a colour differentiation between supplier (red) and SOLARIS (blue) responsibilities. Standard motion systems are those equipped with 2-phase stepper motors with a nominal current up to 7A and encoders supported by IcePAP i.e.: pulse/direction or quadrature (TTL or RS422) or absolute SSI (for BISS- C, contact SOLARIS technical services).

Supplier must follow all rules described in the next chapter.

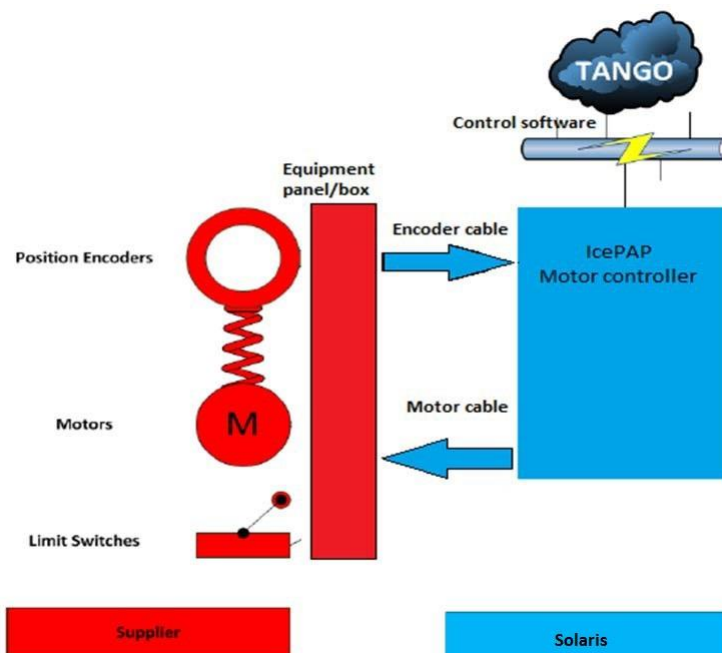

Figure 1. Elements and responsibilities of a standard motion system

3 Standard motion system

3.1 Motors

Standard motion systems are determined by the use of 2-phase bipolar stepper motors up to 7A and encoders supported by IcePAP i.e.: pulse/direction or quadrature (TTL or RS422) or absolute SSI (for BISS-C, contact SOLARIS technical services).

Any other motion system is considered as non-standard and have to follow chapter 'Non standard motion system'.

As described above IcePAP can drive any 2-phase bipolar stepper motor up to 7A (requiring less than 300W in operation). Thanks to its software configurable DC bus (70V-10V) and current loop PID parameters IcePAP has no problem driving low inductance motors (high current or in-vacuum steppers) or high resistance motors.

3.2 Motor connection

The motor connector is a 12-pin MIL-C-26482 compatible shell size 14.

Figure 2 shows pin distribution for different motors.

Connector	Pin	Signal			Description
		1-phase	2-phase	3-phase	
 <p>12-pin female MIL-C-26482 compatible shell size 14 socket</p>	A	Home			Mechanical reference
	B	PhaseA+	PhaseA+	PhaseA	Motor power
	C	PhaseA-	PhaseA-	PhaseB	
	D	n/c			
	E		PhaseB+	PhaseC	
	F	n/c	PhaseB-	n/c	
	G	Disable			
	H	Limit+			Travel limits
	J	Limit-			
	K	Shield			Aux power supply
	L	5Vpower			
	M	GND			
Examples of mating connectors:		ITT CANNON: TNM6U 1400-12P1L FCI: UTGS6PG1412PN			

Figure 2. IcePAP motor connector.

Control lines, i.e.: Home, Limit+, Limit- and Disable share the same electrical interface shown in Figure 3.

All control lines are to be closed via pin M(GND).

Pin A (Home) is foreseen when electrical switches in the equipment will be used as reference mark for homing purposes. For reference signals provided by encoders, there's already a couple of pin inputs available at the encoder interface.

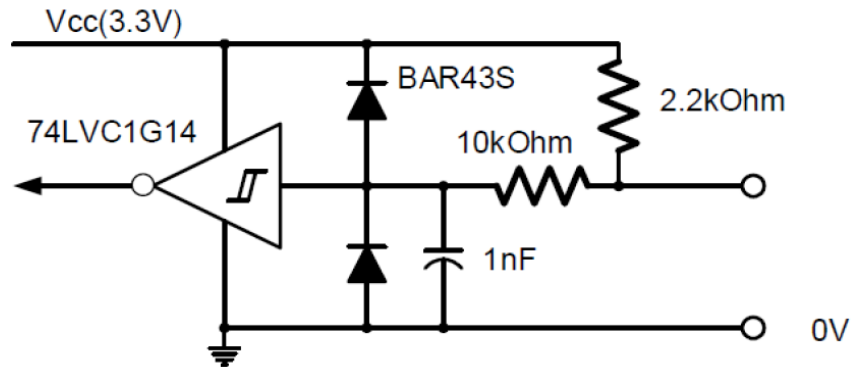

Figure 3. Control lines electrical interface.

Pin L (5V power) should be used to supply active switches.

Pin K is connected to the cable shield and is thought to provide electrical shield continuity in case plastic connectors (discouraged) are to be used.

The signal Disable (Pin G) is always checked by the hardware, and a high level prevents the motor power to be switched on. Even if the equipment to be driven will not use the disable signal functionality, Disable has to be externally connected to GND (i.e. pins G and M have to be connected). A good practice in that case is to connect the disable signal to ground in the last connector before the motor, so that the driver can always detect if the motor is connected or not.

There has to be a clearance of at least 20cm in front of the motor connector for the incoming cable.

3.2.1 Connector code examples (based on Souriau Trim Trio series)

IcePAP controller has a connector Souriau Trim Trio code

UT001412SH Cable on the IcePAP controller side a UT061412PH

Cable on the motorised equipment side will have a UT061412SH

In the motorised equipment patch panel there should be a UT001412PH

Connector codes finishing with SH/PH can end with SH6/PH6 if IP68 is desired.

Other brands of 12-pin MIL-C-26482 compatible shell size 14 equivalent connector are also accepted.

3.2.2 Alternative motor connection for in-vacuum stepper motors up to 2A*

If motor control is in vacuum it is possible to interface it through an in-flange male-male sub-d 15 feedthrough too. In that case pins must be arranged to the configuration in the following table:

Pin in-air	Pin in-vacuum	Motor
1	8	PhaseB-
2	7	PhaseB-
3	6	PhaseB+
4	5	PhaseB+
5	4	PhaseA-
6	3	PhaseA-
7	2	PhaseA+
8	1	PhaseA+
9	15	Limit+
10	14	GND
11	13	Disable
12	12	5Vpower
13	11	Home
14	10	GND
15	9	Limit-

Table 1. In-vacuum motors. In-air flange side male 15 pins sub-D connector pinout.

This table has been updated to place the 5V pin in the center pin, avoiding to damage equipment if a mirroring error happens.

* In case the motor has 8 leads and is wired in parallel using 2 pins per phase, motors up to 4A per phase can use this configuration too.

3.3 Encoders

IcePAP supports both incremental and absolute SSI or BISS-C encoders via its main connector input. Incremental encoders can be pulse/direction or quadrature. For SSI absolute encoders the clock frequency can be set to any value among 125kHz, 250kHz, 500kHz, 1.25MHz, 2.5MHz, 7.5MHz, 12.5MHz and 18.75MHz.

It is possible to add an extra time interval between consecutive SSI frames. That extra time can be chosen to be: 0, 5µs, 10µs, 20µs, 30µs, 50µs, 100µs or 500µs. Data width can be chosen up to 32 bits and the position value must be encoded either as normal binary or Gray code. The SSI module may implement also odd or even parity checking. The parity bit must come as a data bit after the position bits.

Absolute encoders are preferred.

Encoder connection

Figure 4 shows the standard 15-pin sub-D connection configuration for encoders at SOLARIS (9-pin sub-D connections are also supported). External manufactures should adhere to it, especially when an interconnection box will be built into the equipment. Only in specific cases where no interconnection box is foreseen and after requesting written confirmation from SOLARIS staff is needed.

The encoder signals are differential and compatible with RS422 specification (see Figure 4 for electrical interface).

All differential signals are also TTL compatible. In that case, the negative signal has to be disconnected and only the positive signal of the differential pair and the GND pin are to be used as interface.



Connector	Pin	Signal	Type/Direction	Description
 15-pin female sub-D	1	EnclnA+	RS422 input	Encoder signal
	9	EnclnA-		
	2	EnclnB+	RS422 in/out	
	10	EnclnB-		
	3	EncAux+	RS422 in/out	Auxiliary encoder signal
	11	EncAux-		
	4	EncClk+	RS422 out	Encoder clock signal
	12	EncClk-		
	5		n/c	
	13		n/c	
	6		n/c	
	14	5Vsense+	analog input	Aux supply sense
	7	5Vsense-	analog input	
	15	5Vpower	power supply	Aux power supply
	8	GND	power ground	

Figure 4. Encoder connector, type 15-pin sub-D

EnclnA, EnclnB and EncAux are to be used with incremental encoders for signals A, B and Index. EncClk and EncAux are to be used with absolute encoders for Clock and Data inputs. The auxiliary power supply in the encoder connector provides 5V supply to encoders (pins 15 and 8) and also sense lines to compensate for supply cable voltage drops (pins 14 and 7).

The connector on the motorized equipment panel has to be a 9-pin or 15-pin (pinout described in Figure 4) male sub-D connector.

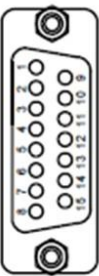
In case of doubt don't hesitate to contact National Synchrotron Radiation Center - SOLARIS technical services.

	Solaris Standards & Recommended Practices	
	Motion control standard	Page 8 of 21
		Date 2021-11-05
Final version	Version: 1.8	

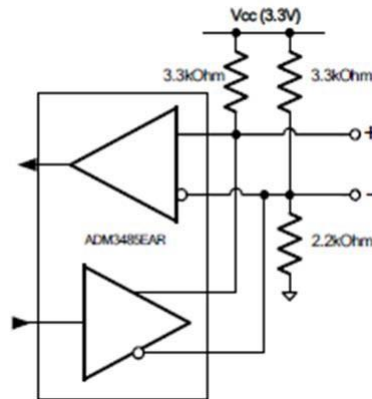



Figure 5. Circuit used for differential RS422 lines (input and output).

PLC encoder connection

In applications where for machine safety purposes it is necessary that an encoder position is checked by the PLC it is recommended to use an SSI absolute encoder. The PLC encoder interface supports the following characteristics:

- Any absolute encoder supporting standard SSI protocol including linear, rotary, and optical distance measuring devices. Most-Significant Bit Aligned data format. Physical interface for clock and data signals is RS-422
- SSI data rates (software selectable): 125 kHz, 250 kHz, 500 kHz, 1 MHz, 2 MHz.
- SSI bits per word: 2...31
- SSI word delay time(dwel time between two position requests): 16 μ s...65535 μ s
- SSI features: Gray or binary code capable with gray to binary conversion
- SSI sensor power: 450 mA, 10...28.8V DC (preferable)

The encoder interface could be according to that in Figure 4, but this is not mandatory.

	Solaris Standards & Recommended Practices	
	Motion control standard	Page 9 of 21
	Final version	Date 2021-11-05
		Version: 1.8

3.4 *Limit or home switches*

As described above, limit or home switches are connected to IcePAP via the motor connector described in Figure 2 and 3.

Standard limit switches meet the following specifications:

- 2 contacts per limit
- Return of the circuit is done via the pin M (GND) pin in the motor connector.
- Activation is defined by their interaction with the input circuitry described in Figure 3.
- 5V supply can be taken from pin L but it must be observed that the inputs already have a 2.2kOhm pull-up to 3.3V. These 5V come from the same supply as the one used for the encoder.
- Normally-closed contact are preferred.

Typically a dry normally-closed contact is satisfactory (as long as the pull-up to 3.3V in Figure 3 can yield an active signal when open). If a sensor based on different technology it should be stated clearly in the documentation. Optical or Hall sensor based switches should be avoided.

The location of the limit switch wired to the positive limit switch pin shall be chosen so that the axis moves towards it when it is actuated in the positive direction.

3.5 *Temperature connectors*

Motors in-vacuum must be equipped with temperature sensors.

The equipment should make available the thermocouples in the equipment or motors via miniature thermocouple connectors (rated -50°C to 220°C).

Examples can be found at:

http://www.tcdirect.co.uk/Default.aspx?level=2&department_id=280/1

For PT100, 3 wire connections should be used.

It is allowed to use several PT100 via a DSUB15 connector.

3.6 *Disable*

There are two possibilities to wire sensors that need to disable the motor power stage depending on whether it is necessary that external electronics (PLC) survey the state of the switches or whether that is not necessary and the switches can be wired in series to the disable pin on the motor interface (this is typically the case when the axis ONLY has overtravel switches). The decision has to be agreed with the equipment responsible on SOLARIS side.

IcePAP provides a pin (G) in its motor connector to allow external hardware to disable the motor power stage for safety purposes. This pin has the same electrical interface as the pins dedicated to positive and negative switches. Normally Closed (NC) contacts must be used.

Any switch that has to be connected to external PLC electronics must be rated to at least 24V and 10mA.

There's a number of situations where this pin should be used:

- Overtravel switches
- Machine/Emergency stop button
- Collision switches
- Disable motor due to temperature beyond a given threshold

	Solaris Standards & Recommended Practices	
	Motion control standard	Page 10 of 21
		Date 2021-11-05
Final version		Version: 1.8

3.6.1 Disable with no need of external electronics

This is the typical case when the axis has ONLY two overtravel end-switches (not to confuse with the limit switches) and there is no need to know externally the independent state of each switch, overtravel switches can to be wired in series between the motor connector disable pin (G) and the motor connector ground pin (M).

3.6.2 Disable with need of external electronics

In this case if the axis has to be disabled (or it might be disabled in the future according to the equipment responsible), it will be done via a PLC (that might be provided by National Synchrotron Radiation Center - SOLARIS). Electrically, this means that the signals/switches giving the alarm condition have to be wired to the PLC and that the PLC has to activate the disable pin in the motor axis connector. The equipment will use one 9 pin Sub-D connector (male).

Pins 1 and 2 of Sub-D connector will be wired to the G and M pins of the motor connector, allowing the PLC to activate this signal. The rest of the pins are available for the equipment manufacturer to make accessible all the switches or signals that have to be surveyed by the PLC.

Limit switches used for axis disable conditions via external electronics must be replicated via this connector.

It is possible to group signals related to different axes in the same Sub-D connector to reduce the number of connectors. In that case pinout is to be decided by the manufacturer and approved by SOLARIS later.

Due to the extra overhead that is required to add the disable screw terminals at a later stage, it is **STRONGLY RECOMMENDED** to add it in the beginning in case of doubt. This shouldn't be done as default practice though and be kept only to axes that need/might need the disable for some reason.

See wiring examples for several cases in Appendix A.

4 Non-standard motion systems

Non-standard motion systems are those whose motor is not a 2-phase stepper with nominal current up to 7A (requiring less than 300W in operation) or whose encoder output is not supported by IcePAP i.e.: others than pulse/direction or quadrature (TTL or RS422) or absolute SSI (for BISS-C, contact SOLARIS technical services) or need a supply current higher than 0.5A, for example.

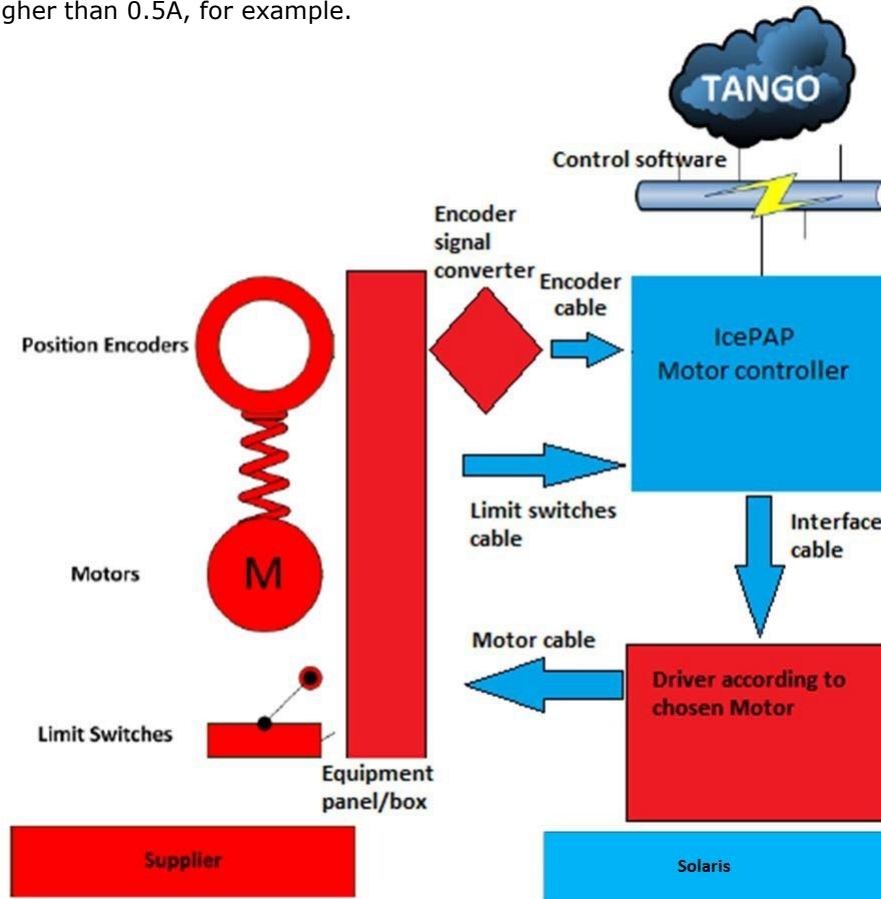

Figure 6. Elements and responsibilities of a standard motion system

Concerning non-standard motors, the approach for interfacing is different when an external controller (intelligent programmable motion controller) is used to interface the motor (typically Brushless DC motors) or when a simple power driver stage is used (3 or 5 phase stepper motors). The second case is discussed in this chapter.

Non-standard motor drivers can be driven from IcePAP via its quadrature (or pulse/direction output). Quadrature is preferred (pulse/direction drivers often impose a time before switching direction and IcePAP does not support that option). Each IcePAP driver can forward its internal indexer pulses to any external driver that can be steered via pulse and direction or quadrature via its front axis interface keeping at the same time synchronization capabilities with the rest of the IcePAP system. It is up to the supplier to find a suitable external power driver for his motor.

In the front axis interface connector, 3 TTL 3.3V can be configured to output information to the driver like power on/off (InfoA), brakes (InfoB) or changing step resolution (from full step to some factor of microstepping). Limit switches must in this case be wired to the motor interface of the IcePAP driver connected to the external driver. A connector has to be foreseen for that purpose in the equipment interface panel or box. If the limit switches are needed by the external driver, IcePAP can forward those limit signals to the external driver via the 3 TTL 3.3V outputs mentioned above.



Connector	Pin	Signal	Type/Direction	Description
 <p style="text-align: center;">25-pin female Sub-D</p>	1	+3.3V	power supply	See 2.2.2.1
	14	(reserved)		
	2	Tx232	RS232 I/O	Asynchronous serial port
	15	(reserved)		
	3	Rx232		
	16	GND		
	4	OutPosA+	RS422 output	Output position signal
	17	OutPosA-		
	5	OutPosB +	RS422 output	Auxiliary output signal
	18	OutPosB-		
	6	OutAux+	RS422 output	Auxiliary output signal
	19	OutAux-		
	7	GND		
	20	InPosA+	RS422 or TTL input	Input position signal
	8	InPosA-		
	21	InPosB+	RS422 or TTL input	Auxiliary input signal
	9	InPosB -		
	22	InAux+	RS422 or TTL input	Signal ground
	10	InAux-		
	23	GND		
	11	GND		
	24	InfoA	TTL Output (3.3V)	General purpose output
	12	InfoB	TTL Output (3.3V)	General purpose output
	25	InfoC	TTL Output (3.3V)	General purpose output
	13	GND		Signal ground

Figure 7: Front axis connector pinout

The quadrature (or pulse/direction) output is obtained from two differential pairs (according to RS422 standard) OutPosA (pulses) and OutPosB (direction). These signals can drive TTL inputs too leaving the negative pin of the pair disconnected and closing the circuit via GND (pin 7) (leaving the negative pin of the pair disconnected).

In order to use non-standard encoders, the supplier has to provide some kind of converter to the supported encoder signals. It is strongly recommended that you contact before SOLARIS technical services.

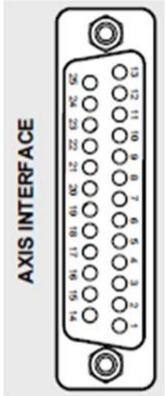
	Solaris Standars & Recommended Practices	
	Motion control standard	Page 13 of 21
		Date 2021-11-05
Final version	Version: 1.8	

5 Dampers

Mechanical dampers have become very common recently in all motor manufacturers catalogs. These inertial bodies filled with hermetically sealed silicon gel suppress stepping motor vibrations and improve high-speed performance allowing steppers to transition through the typical middle frequency resonances at few kHz into the 10kHz region for a very low price.

In systems where high rotary speed is required, National Synchrotron Radiation Center - SOLARIS recommends the use of double shaft motors with one of these dampers attached to the second shaft.



Figure 8. Inertial dampers from two motor manufacturers

6 Brakes

It is strongly recommended to design the mechanics in a way brakes are not necessary. The standard SOLARIS driver does not offer any 'Safe-Torque-Off' certified functionality.

	Solaris Standars & Recommended Practices	
	Motion control standard	Page 14 of 21
		Date 2021-11-05
Final version	Version: 1.8	

7 Cabling

The standard cable used at National Synchrotron Radiation Center - SOLARIS to join motor interface at controller and the motor connector at the equipment has the following characteristics:

- 2x2x0.75mm² for the motor phases. Shielded.
- 2x3x0.34mm² for the control lines (limits, home, disable, 5V, gnd). Shielded.
- Overall shield. Outer sheath PUR, halogen free.

Equipment internal cabling does not have to comply with this, but it should be taken as reference for shielding and wire diameters.

The standard cable used at National Synchrotron Radiation Center - SOLARIS to connect encoder interface at controller and the encoder connector at the equipment has the following characteristics:

- 6x2x0.25mm² LIYCY cable. Shielded. (Match differential signals with twisted pairs).

Equipment internal cabling does not have to comply with this, but it should be taken as reference for shielding and wire diameters.

All metallic connector plates must be adequately connected to ground of the equipment.

Machine wiring must meet the EU Low Voltage Directive 2014/35/EU and EU EMC directive 2014/30/EU.

Cabling best practices must be followed. Cable shielding should reach to the motor enclosures. All metallic connector plates must be adequately connected to a single functional ground terminal. Cables and shields (especially from encoders) should not be interrupted by intermediate connectors unnecessarily, and shields (especially from encoders) should not be broken from the encoder till the final equipment connector. Cables must be protected against mechanical damage by running the cables or wires in conduit, flexible conduit, metal braid, cable trunking, etc. Cables have to be protected against damage from the edges via glands, bushes etc. Cable routing systems from painted, coated or plastic cable tray, non low smoke zero halogen material or simple cable ties are not accepted. Cable routing systems shall not be fixed via adhesive fixings unless holes can't be drilled in a specific surface.

	Solaris Standars & Recommended Practices	
	Motion control standard	Page 15 of 21
	Final version	Date 2021-11-05
		Version: 1.8

8 Documentation

The manufacturer/supplier will provide, for each axis, a table with at least the following information:

- Motor:
 - Full model name
 - Current, idle current, step resolution (half step, microstepping factor), speed recommended and maximum speed for the equipment
 - Steps from home to limit switches or between limit switches and limit switch to start homing from
 - Backlash
 - Disable sources
- Encoder:
 - Full model name
 - Type: Incremental or absolute
 - Encoder counts from home to limit switches or between limit switches if encoder is incremental or encoder position of the limit switches if the encoder is absolute
- Limit switches:
 - Full model name
 - Type: Dry contact or other technology

SOLARIS will provide an excel sheet with the structure for all the information listed above. Besides, Supplier will provide manufacturer datasheets for all motors, encoders, switches and other related elements used in the system. See Appendix 10.3

	Solaris Standards & Recommended Practices	
	Motion control standard	Page 16 of 21
		Date 2021-11-05
Final version	Version: 1.8	

9 Summary

Standard motors	2-phase bipolar steppers
Standard motors nominal currents	Up to 7A, 300W max per axis
Driver DC bus	Software configurable from 75V down to 10V
Incremental encoder technologies	Pulse/direction or quadrature (TTL or RS422)
Absolute encoder technologies	SSI, BISS-C (up to 32 bits), PREFERRED SOLUTION
Encoder voltage supply provided by controller	5VDC, 500mA
SSI clock frequencies	125kHz, 250kHz, 500kHz, 1.25MHz, 2.5MHz, 7.5MHz, 12.5MHz and 18.75MHz
SSI data	Up to 32 bit
SSI others	Gray or binary. Odd or even parity bit after data
Limit switch voltage ratings	Interface is based on 2k20hm pull-up to 3.3V
Thermocouples	Miniature thermocouple connectors (rated to 220 °C)
External driver output	Pulse/direction or quadrature (TTL or RS422) (3.3V)
High speed axis	Inertial dampers on 2 nd shaft recommended
Disable signals	In case of doubt add a connector for that purpose
Axis direction (positive limit location)	It should be chosen in a way that axis moves towards it when it is actuated in the positive direction
Connector codes (Soriau series)	
Motor connector in a motorised equipment's patch panel	UT001412PH or UT001412PH6
Disable connector in a motorised equipment's patch panel	Screw terminals
Encoder connector in a motorised equipment's patch panel	15 pin sub-d male

10 Appendix A

10.1 Standard motion system. Motor connector wiring example

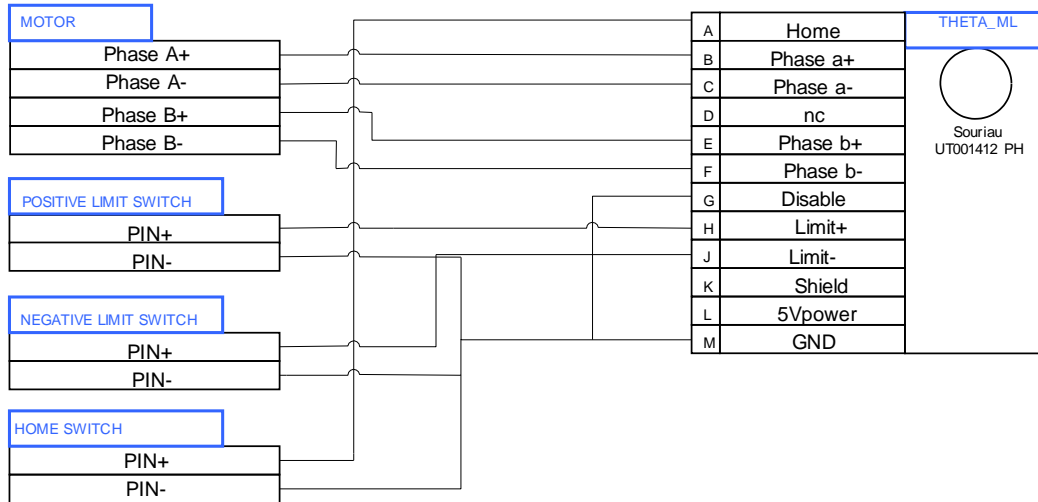

Figure 9. Interface box wiring diagram on motorised equipment.

10.2 Standard motion system. Disable connection wiring examples

10.2.1 Overtravel or safety switch limits to PLC and from there to IcePAP

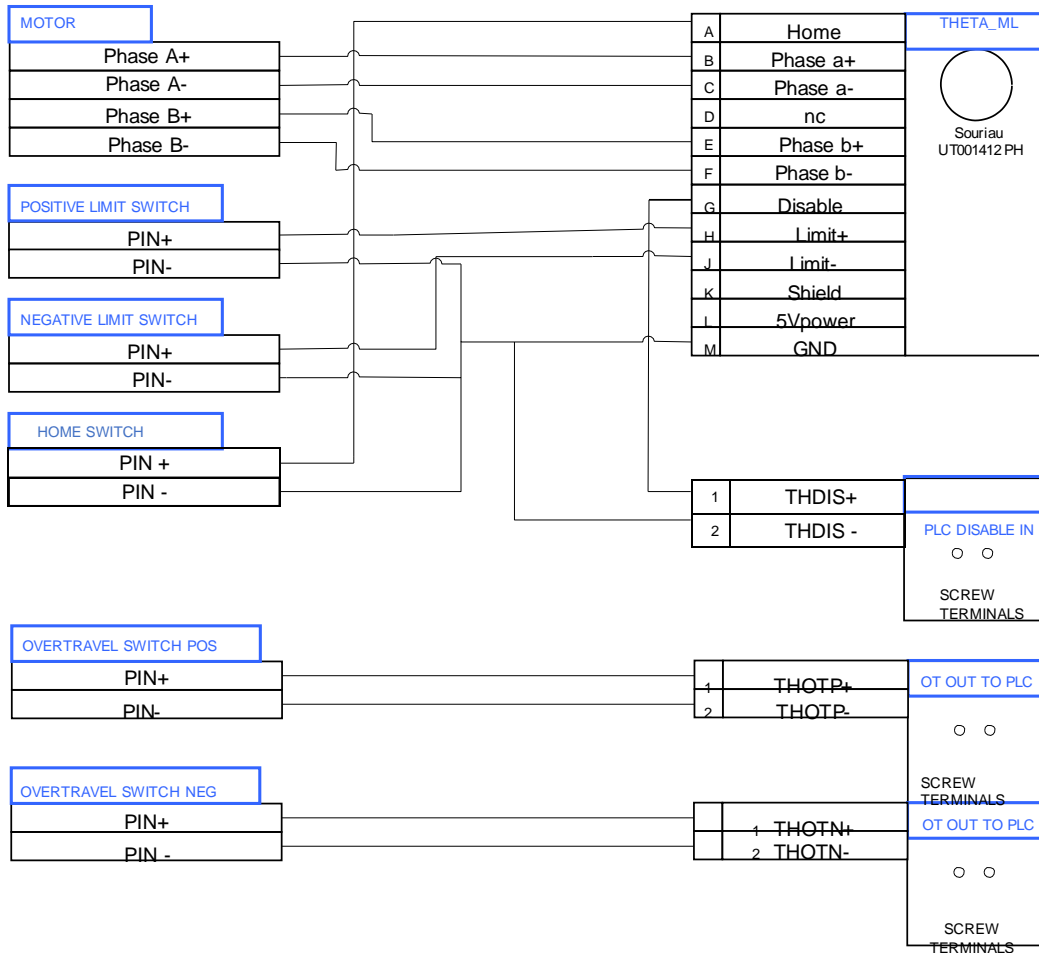

Figure 10. Interface box wiring diagram for overtravel PLC disabled axis

10.2.2 Overtravel or safety switch limits direct to IcePAP

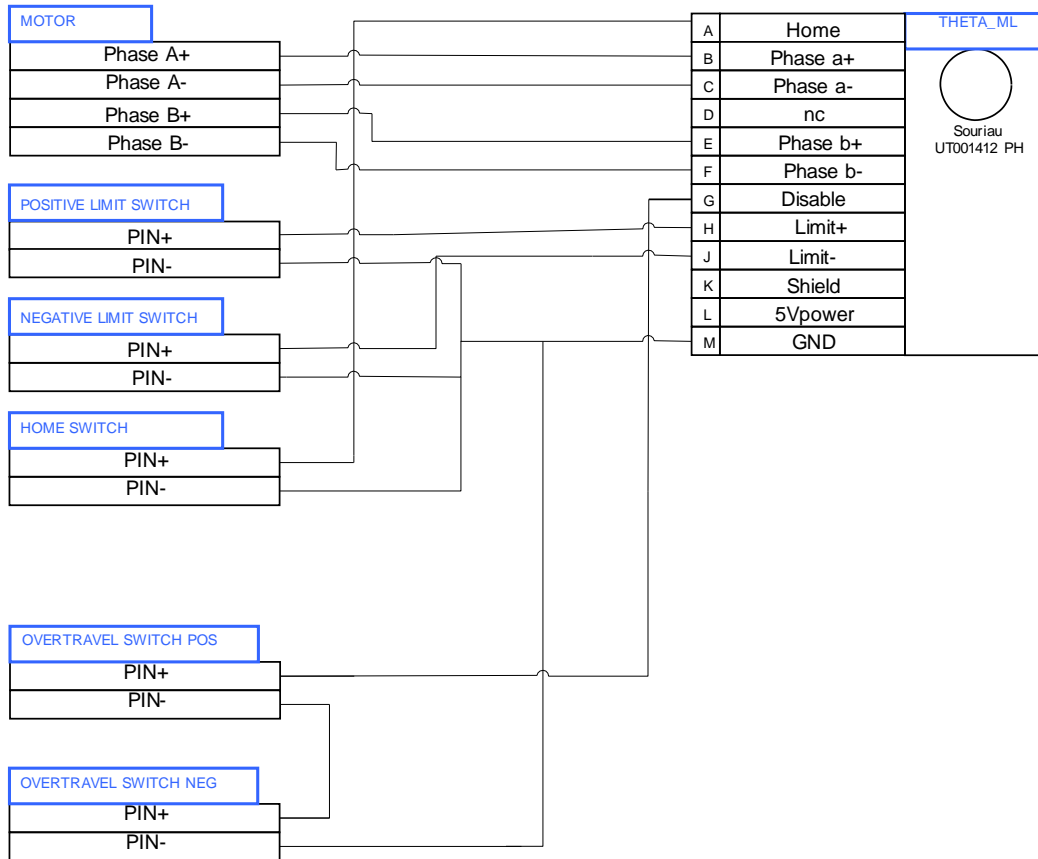



Figure 11. Interface box wiring diagram for overtravel disabled axis without external hardware

10.3 Motion parameters (template)

Group of parameters	Parameter description	Related IcePAPCMS variables	
General parameters	Axis name or number	AXIS	
	Motor steps per turn	MOVEMENT RESOLUTION	
	Nominal motion speed (steps per second)	VELOCITY	
	Maximum motion speed (steps per second)		
	Time to reach nominal velocity (Acceleration time)	ACCELERATION TIME	
	Number of phases	PHASES	
	Regulation mode: Current, Voltage, Torque; IcePAP supports only Current	REGULATION MODE	
	Resistance of single phase (ohms)	PHASE RESISTANCE	
	Nominal motion voltage	NOMINAL VOLTAGE	
	Voltage required to keep axis stationary (as percentage of nominal value)	IDLE VOLTAGE	
	Nominal motion current	NOMINAL CURRENT	
	Current required to keep axis stationary (as percentage of nominal value)	IDLE CURRENT	
	Encoder data format (QUAD, PULSE+, PULSE-)	ENCODER MODE	
	Encoder steps per turn	ENCODER RESOLUTION	
	Positive limit signal polarity	L+ POLARITY	
	Negative limit signal polarity	L- POLARITY	
	Home signal polarity (only if homing is done via encoder)	HOME POLARITY	
	Maximum velocity for home search	HOME SEARCH VELOCITY	
Absolute encoder	Direction		
	Offset		
	Transmission type		
	Transmission parameters	Data length	
		Data coding	
		Clock frequency	
		Control bit pattern	
Motor	Full model name		
	Steps from home to limit switches or between limit switches and limit switch to start homing from		
	Backlash		
	Disable sources		
	Full model name		
	Type: incremental or absolute		

	Solaris Standars & Recommended Practices	
	Motion control standard	Page 21 of 21
	Final version	Date 2021-11-05
		Version: 1.8

		Encoder counts from home to limit switches or between limit switches if encoder is incremental or encoder position of the limit switches if the encoder is absolute	
Limit switches		Full model name	
		Type: dry contact or other technology	